



EV CHARGING ⚡

MASTERPLUG SOCKETED & TETHERED SMART EV CHARGERS



 TYPE 2	 5m CABLE	 7.4kW MODE 3
 32A/230V SINGLE PHASE	 IP55 RATING	 IK08 RATING
 Wi-Fi	 Bluetooth	 3 YEAR WARRANTY

2 Models Available
Socket or 5M tethered options

Quick & easy installation
with UK based technical support

3 year warranty
fully compliant with UK EV regulations

Compatible
with all electric and hybrid plug-in vehicles

- **Connect** via Wi-Fi or LAN
- **Fully compliant** with The Electric Vehicles (Smart Charge Points) Regulations 2021, including Schedule 1
- **Full Smart! charging** via the Monta App
- **Dynamic charging** up to 7.4KW (32A)
- **No earth rod required**, integrated open PEN conductor protection
- **Safe** with a Integrated Type A RCD with 6mA DC detection
- **OCCP 1.6J** connectivity
- **Type 2 Socket** with Auto-Lock or 5M tethered options

CHARGE-POINT APP

Included at no additional cost, Monta lets you tailor your EV Smart Charging needs. Have full control over your charge-point; deciding who can use it, when and at what cost

- Smart charging**
- Self-healing**
- Solar charge ready**
- Roaming**
- 24/7 app support**
- Share & monetise your charger**



RANGE FEATURES

CODES :	S7 SOCKET EVCM3SS7B
	T7 5M TETHERED EVCM3ST7B
SOCKET / PLUG :	TYPE 2 CONNECTOR
CHARGE CURRENT :	CONFIGURABLE 6-32A
INPUT VOLTAGE :	220-240V 50-60HZ SINGLE PHASE
COLOUR :	BLACK - RAL9005
IP / IK RATING :	IP55 / IK08
MATERIAL :	UV RESISTANT POLYCARBONATE
WALL FIXING :	4 POINT FIXING WITH HORIZONTAL AND VERTICAL ADJUSTMENT. SUPPLIED WITH FIXING HOLE TEMPLATE. FIXING CENTRES - 110MM X 145MM
CABLE MANAGEMENT :	INTEGRATED CABLE STORAGE
OPERATING TEMP :	-25°C TO + 50°C, INTEGRATED THERMAL PROTECTION
INCLUDED ACCESSORIES :	LOAD MANAGEMENT CLAMP, 1X25MM COMPRESSION GLAND, 1X25MM BLIND GROMMET, ANTI-TAMPER DRIVER BIT, POWER CONNECTORS AND 5X BASE FIXING WASHERS

DIMENSIONS :

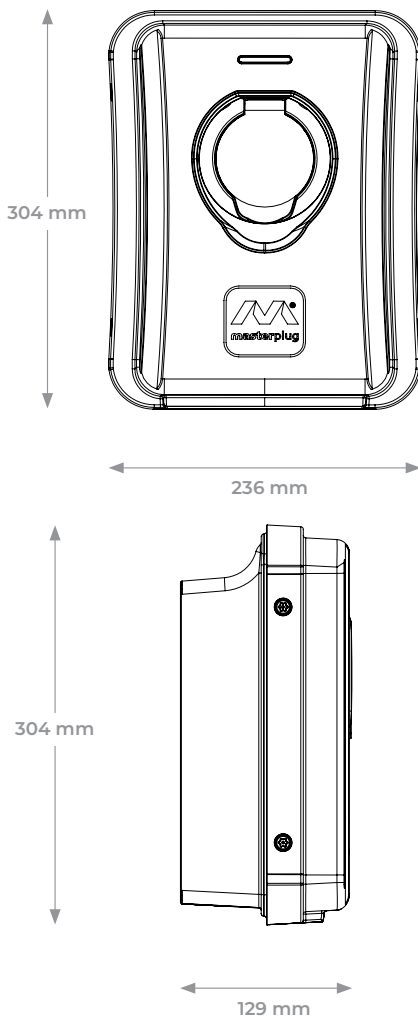

NETWORK AND CONNECTIVITY

WI-FI :	2.4GHZ 802.11 B/G/N
WI-FI SECURITY :	WPA/WPA2/WPA2-ENTERPRISE
ETHERNET :	RJ45, SUPPORTS DHCP AND MANUAL STATIC IP ADDRESS
CONNECTION PROTOCOL :	OCPP 1.6J
BLUETOOTH :	EASY SET UP VIA BLUETOOTH INSTALLER APP, 4.2BR/EDR AND BLE
APP :	POWERED BY MONTA USER APP

ELECTRICAL AND SAFETY

PEN PROTECTION :	YES, INTEGRATED EARTH DISCONNECTION
EARTH ROD :	NOT REQUIRED, SUPPORTS TT, TN C-S, PME
RCD PROTECTION :	YES, INTEGRATED 6MA DC AND 30MA AC TYPE A
ELECTRICAL CLASS :	CLASS 1, WITH CLASS 2 HOUSING FOR PEN FAULT PROTECTION
LOAD MANAGEMENT :	SUPPLIED WITH LOAD MANAGEMENT CLAMP, SUPPORTS UPTO 120A CIRCUITS
METER ACCURACY :	2% CLASS C EQUIVALENT INTERNAL METER, SUPPORTS EXTERNAL RS485 MODBUS METER
CONSUMER UNIT REQUIREMENTS :	40A MCB OR 30MA TYPE A RCBO (DEPENDENT ON CABLE TYPE AND/OR ROUTE)
TERMINALS :	COMBI SCREW FIRST FIX POWER PLUG
INDICATOR :	RBG LED AND BUZZER BLUE - STANDBY FLASHING BLUE - PREPARING GREEN - CHARGING FLASHING GREEN - CHARGE FINISHED YELLOW - NO NETWORK RED - ERROR
WARRANTY :	3 YEAR STANDARD WARRANTY
STANDARDS AND APPROVALS :	IEC61851-1, IEC61439-7, IEC 62955, IC 61851-21-2, BS EN62196, EN301 511, EN 301 908-1/2/13, EN 301 489-3, EN 300 330, EMC COMPLIANT, THE ELECTRIC VEHICLES (SMART CHARGE POINTS) REGULATIONS 2021 INCLUDING SCHEDULE 1